

## HYDRAULIC MOTOR OF HIGH TORQUE WITH CYLINDERS AND CRANKSHAFT

By

G. ARIAS-POLO

*Cuban Sugar Research Institute*

[gariaspolo@yahoo.com.mx](mailto:gariaspolo@yahoo.com.mx)

**KEYWORDS: Hydraulic Motor, High Torque Motor,  
Multi Cylinder Motor.**

### Abstract

THE PAPER describes a new design of hydraulic motor for high torque and low speed applications. This design involves no speed reduction between the motor and the driven equipment. The motor is simple to manufacture as it uses components of common technology, with low cost and little complexity. It consists essentially of three double effect hydraulic cylinders and a rotary flow valve, all supported on a frame. It has the patented novelty that the three hydraulic cylinders carry out useful work in both directions, giving it a higher torque/mass density. A prototype motor has operated during one season in Havana Libre Sugar Mill of Cuba, with very promising results. The design of a new more robust model, promising better performance than the experimental prototype, is also presented.

### Introduction

In the late 1970s, the Swedish company 'Häggglunds' introduced their High Torque, Low Speed (HTLS) hydraulic motors into Cuba (Per-Owe, 1981). The motors did not require any speed reduction between the motor and driven equipment. These motors have been used in the sugar industry in applications such as sugar crystallisers, cane conveyors, winches, mills crushing trash, big lathes and cane mills.

The main advantages of these motors were reported by Arias-Polo (2008b), Lewinski (2002a), Lewinski (2002b), Lewinski (2006) and Ljung (2006):

- a) Direct coupling of drive to equipment without speed reduction.
- b) Low assembly costs. Foundation is not needed.
- c) Decrease of power loss in transmission.
- d) Decrease of the required space. High torque/mass density
- e) Wide speed range without gear ratio change.
- f) Full torque at zero speed for indefinite time.
- g) Can cope with frequent starts and stops.
- h) Energy saving since power is not consumed unless required.
- i) Low inertia (1% of conventional drive). The over loads and impact loads are controlled by a simple relief valve.
- j) Long life, high technical reliability and low maintenance.
- k) Reverse direction simple way achieved.

In several applications such as cane conveyors, pumps and fans, the working load has significant variability during its duty cycle. HTLS motors have advantages in these applications to achieve a considerable energy saving and softness in operation as described by Lewinski (2006) and Ljung (2006). These advantages are achieved by means of an automatic closed loop that controls the speed irrespective of the load. The low inertia mentioned above allows faster automatic control

than other alternatives that use mechanical speed reduction steps. When frequent stopping and starting are required, particularly in combination with high loads, hydraulic drives are the most suitable. These advantages of hydraulic drives have been demonstrated by Hägglunds in Cuba over more than 28 sugar harvest seasons.

Financial difficulties in the sugar industry have limited the further uptake of this valuable technology. With the objective of finding an economically viable and technically feasible alternative to existing HLTS motors, the author developed a novel hydraulic motor of high torque and low speed that is presented in this paper.

### Background to the invention

The author carried out a literature search to look for solutions that met the objective of an economically viable and technically feasible alternative to existing HLTS hydraulic motors. One partial solution was identified, consisting of a two cylinder hydraulic motor applied to vertical crystallisers as described by Cameco Industries (1997), DDS Crystalliser (1995) and Groupe Fives-Lille (2002). From these references and the well-known classical steam engines, the author has improved the basic layout by using an odd number of cylinders to smooth the delivered power to the driven equipment.

Additionally, to increase the reliability of the new invention and its compactness, the author investigated the use of flow directional rotary valves that are widely used by companies such as Ebara Man. Co. (1998), Kawasaki Hydraulic Products (1999) and SAI s.p.a. (2004), and adapted this technology to the new design. This adaptation, to allow the cylinders to produce useful work in both directions, is not widely known.

### Description of invention

This new hydraulic motor design has been patented (Arias-Polo, 2006). The design concept is shown in Figure 1.

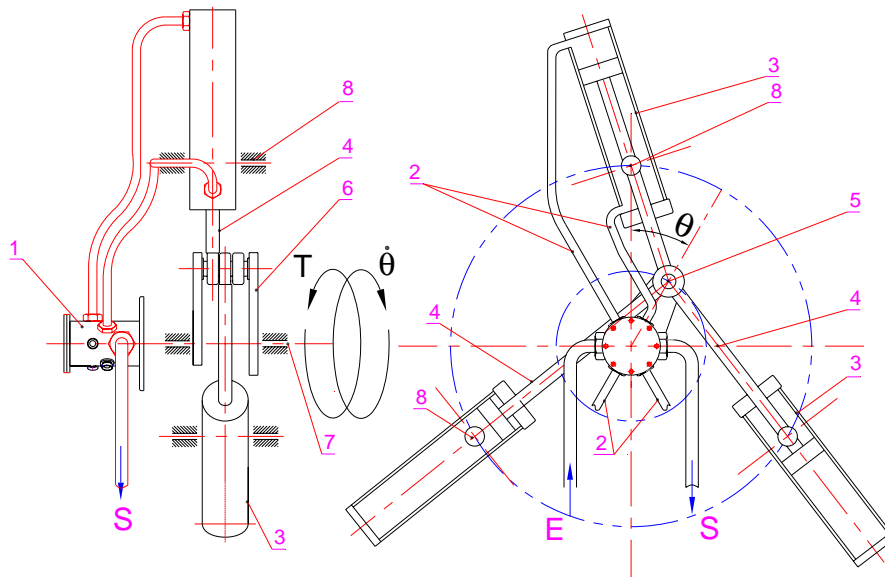

Fig. 1—Simplified drawing of the invention.

The invention is a three cylinder hydraulic motor with a common point of action of forces 5. The hydraulic fluid, supplied by a pump, enters the directional rotary valve 1 at entrance E. This rotary valve 1 moves together with the crank 6, controlling the flow of fluid to the three cylinders 3 and, consequently, the sequence of operation and synchronisation of the cylinders. The fluid enters and leaves the cylinders through the lines 2. The stroke of the cylinders is transferred into rotational motion through the connecting rods 4. The ends of connecting rods are articulated in 8 and 5,

causing the rotation of the crankshaft 6, rotating the driver shaft 7 where useful torque is applied to the driven equipment with the angular speed  $\dot{\theta}$ . The return of hydraulic fluid to the oil tank is also controlled through the rotary valve 1 through the exit S.

The patented technological novelty of this invention is that cylinders carry out useful work in both directions of their stroke. This feature enables the invention to achieve a higher torque to mass ratio compared to similar motors, with the additional advantages of smaller size, weight and cost.

### Experimental development under industrial conditions

Based on the design presented by Arias-Polo (1998), a prototype was built by TANACEN in Cuba, a manufacturing plant belonging to the Cuban sugar industry. The prototype was installed in Havana Libre mill in Cuba, on a Blanchard Crystalliser of 34 m<sup>3</sup> rotating at a speed of up to 2 rpm (Figure 2), with promising results (Table 1). The equipment processed C massecuite successfully at different speeds (0.5, 0.75, 1.0 and 2.0 rpm), having to stop, after more than 300 operating hours, because of the end of the harvest season.



Fig. 2—Prototype operating under industrial conditions.

Table 1—Main experimental data.

Parameter	Symbol	Value	Unit
Motor Displacement	Dm =	43.8	L/rev.
Available motor torque	Td =	50 325.0	N·m
True motor torque	Te =	22 519.0	N·m
Maximal motor speed	nm =	2.0	rpm
Torque motor used	U =	44.7	%
Brake motor power	Ne =	4.7	kW
Pressure motor entrance	P1 =	30.5	bar
Pressure motor outlet	P2 =	7.0	bar
Flow to the motor	Q =	133.6	L/min

### Design improvement

After the operational experiences of the first prototype, the author developed a new design (Arias-Polo, 2002), to increase robustness and to achieve the maximum possible torque within the same motor casing). The diameter of the pistons and connecting rods, the driver shaft and the diameter of the shaft at the end of the three connecting rods were the most important parts updated.

The new design also incorporated a shrink disc coupling that doesn't require keys or splines, allowing quicker assembly and higher strength.

A full mathematical model and the corresponding software for the motor design and performance were described by Arias-Polo (2008a). Applying the model to the new design, new design parameters were obtained. A graph of available motor torque  $T1(\theta)$  vs.  $\theta$  (rotation angle in radians) is presented in Figure 3. The average value VM is also shown. Table 2 shows the design specifications, based on the minimum torque shown in Figure 3.

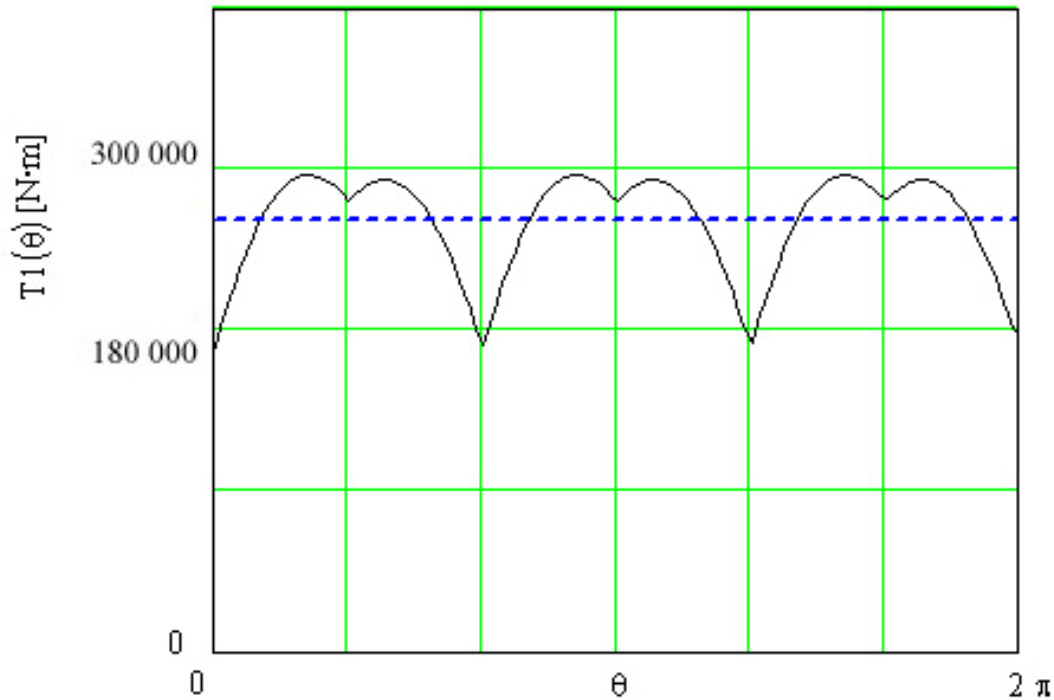

Fig. 3—Torque available from improved design.

**Table 2**—Data for the new design.

Pressure	300.0	[bar]
Torque efficiency	97.0	[%]
Torque available	180 000.0	[N·m]
Specific Torque	600.0	[N·m/bar]
Mass	1360.0	[kg]

### Comparison of new design with current market leaders

From Häggglunds motor data, as presented by Häggglunds Drives (2002) and Lewinski (2002b), the author built performance curves, like that shown in the Figure 3, for four motor models.

A summary of the results, compared to the new design is presented in Table 3. Figure 4 shows the torque vs mass relationship. Interpolating the relationship for the Häggglunds motors, one can observe that the new design weighs about 30% less (1360 kg) than a Häggglunds motor design matching the torque of the new design (1975 kg).

**Table 3**—Comparison of new design with motors from market leader.

Motor type	Torque maximum [N·m/bar]	Pressure maximum [bar]	Torque maximum [N·m]	Mass [kg]
MB 283	283	350	99 050	1395
MB 400	400	350	140 000	1625
MB 566	566	350	198 100	2108
MB 800	800	350	280 000	2580
New Design	600	300	180 000	1360

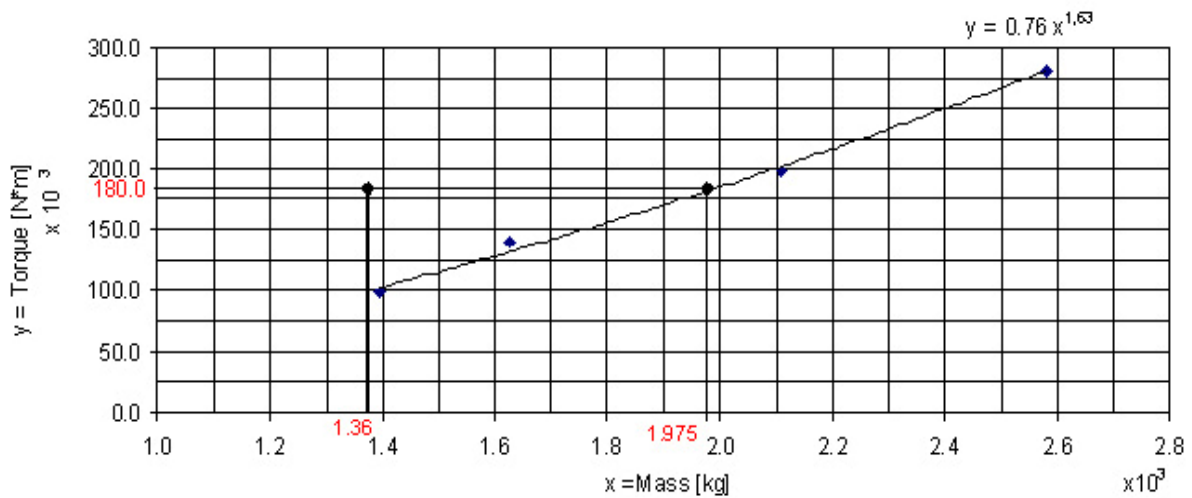

Fig. 4—Comparison between the new design and the leader in market.

**Further improving the available torque**

The available torque can be increased by reducing the torque fluctuations through a revolution of the shaft, such as shown in Figure 3. To achieve this objective, an increase in the number of pistons is proposed, using two motors applied to the driven equipment, with different phases, as shown in Figure 5. Figure 6 shows the resulting performance.

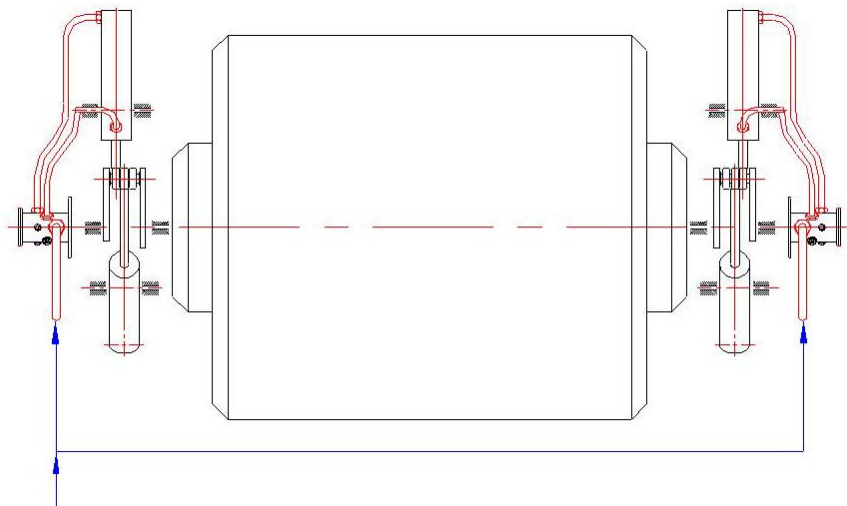

Fig. 5—Two motors applied in each extreme.

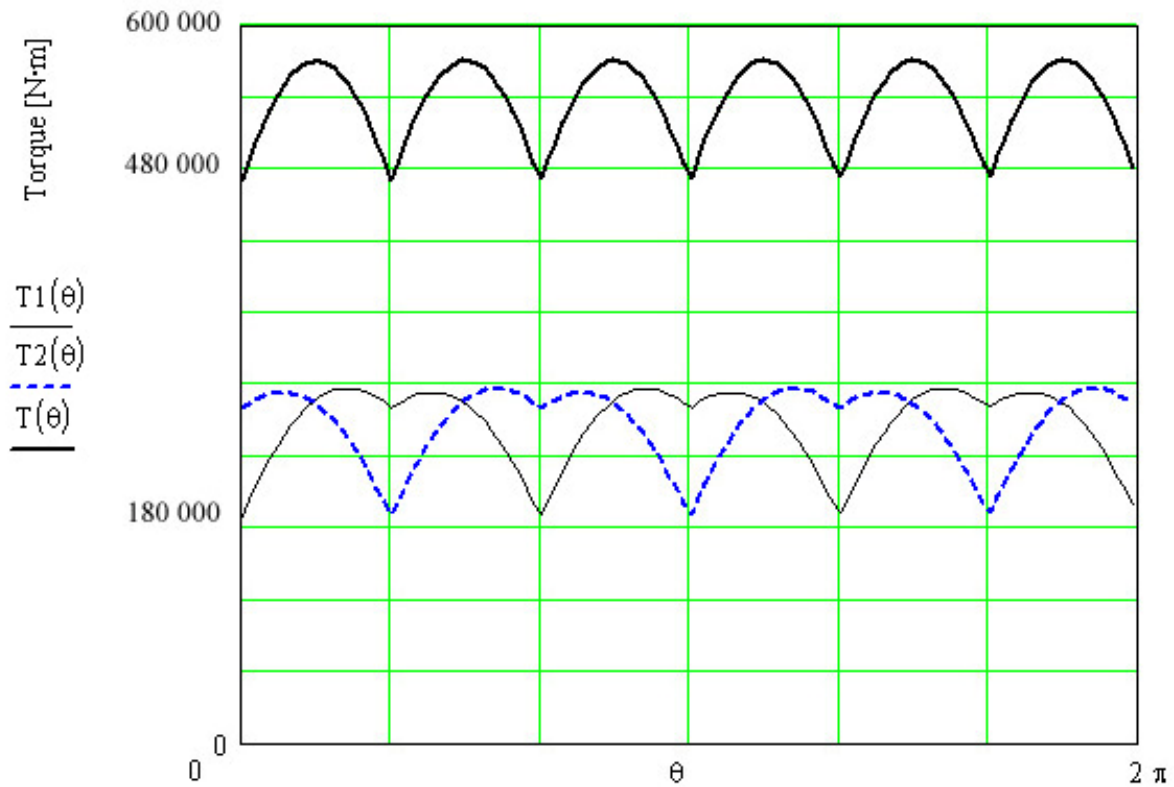

Fig. 6—Available torque for two motors working together with different phases.

The available torque for two motors (the minimum value in Figure 6) with 95% torque efficiency is  $T = 445\,880\text{ N}\cdot\text{m}$ . The torque for each motor is now  $T/2 = 222\,940\text{ N}\cdot\text{m}$ , 23.85% higher than the  $180\,000\text{ N}\cdot\text{m}$  shown in Table 2.

### Conclusions

A new design of High Torque Low Speed hydraulic motor has been developed, with the patented novelty that cylinders carry out useful work in both directions of their stroke. That performance enables the invention to achieve a higher torque to mass ratio than existing motor designs, with the additional advantages of reduced size, weight and cost.

A prototype design was tested under industrial conditions in the Havana Libre Mill in the Republic of Cuba.

With the acquired experience, a new design was developed that modelling has shown has a mass that is less than 70% that of similar motors in the market.

In order to improve the torque to mass ratio further, a configuration is offered by increasing the number of pistons using two motors, with different phases. In this configuration, the torque for each motor will be 23.85% higher than when only one motor is used.

The simple mechanical construction allows the motor to be manufactured in a shop belonging to the Cuban Sugar Industry.

### REFERENCES

Arias-Polo, G. (1998). Proyecto Motor Hidráulico de Alto Torque y Baja Velocidad MH. Empresa de Diseño Mecánico (EDIMEC), MINAZ.

- Arias-Polo, G.** (2002). Proyecto Motor Hidráulico MH2. ICINAZ.
- Arias-Polo G.** (2006) Motor Hidráulico de Alto Torque utilizando cilindros hidráulicos y cigüeñal. Patente de invención OCPI. Certificado No. 23180/ 2006
- Arias-Polo, G.** (2008a). Motor hidráulico de alto torque utilizando cilindros hidráulicos y cigüeñal. Tesis de doctorado en proceso. Cuba.
- Arias-Polo, G.** (2008b). Sistemas de Accionamiento Hidráulico. Teoría y Práctica. Libro de texto. Ediciones Azucareras. Ciudad de la Habana. Cuba.
- Cameco Industries.** (1997). Revista Sugar Journal. Pag. 15. Octubre.
- DDS Crystalliser.** (1995). Engineering Division. DK-1001 Copenhagen K.
- Ebara Man. Co.** (1998). Radial Piston Type Low Speed High Torque. Cat. No. 2798.
- Groupe Fives-Lille.** (2002). Vertical Continuous Crystalliser. FCB Sugar Division 1994.
- Hägglunds Drives** (2002). Product Manual MARATHON. EN395-5h.
- Kawasaki Hydraulic Products** (1999). Sharing the future. Catalogue Abril/99.
- Lewinski, J.** (2002a). Accionamiento Electro hidráulico de la masa cañera. Evento Diversificación 2002. Hotel Habana Libre. Cuba.
- Lewinski, J.** (2002b). Nuevos Desarrollos de Mandos Hidráulicos de Molinos en la Industria Azucarera. Documentos publicados por Hägglunds Drives AB.
- Lewinski, J.** (2006). Accionamientos Electro-Hidráulicos Asistidos para Molinos. Hägglunds Drives AB.
- Ljung, B.** (2006). Hägglunds Drives AB. Hydraulic Drives in Milling Applications. ISSCT ENGINEERING WORKSHOP MEXICO, 21–24 November.
- Per-Owe, T.** (1981). Transmisiones Hidráulicas de Hägglunds en la industria azucarera cubana. Internal report. Hägglunds Drives.
- SAI s.p.a.** (2004). Hydraulic Motor High torque radial piston. Catalogue 878831.

## MOTEUR HYDRAULIQUE DE COUPLE ELEVE AVEC CYLINDRES ET ARBRE

Par

G. ARIAS POLO

*Institut de Recherche Sucre Cubain*

[gariaspolo@yahoo.com.mx](mailto:gariaspolo@yahoo.com.mx)

**MOTS CLEFS: Moteur Hydraulique,  
Couple Élevé, Cylindres Multiples.**

### Résumé

ON PRÉSENTE un moteur hydraulique d'une nouvelle conception; le moteur donne un couple élevé et des vitesses réduites. Il n'est pas nécessaire de réduire la vitesse entre le moteur et l'appareil qu'il conduit. La construction du moteur et sa technologie sont simples ; les coûts sont réduits. Le moteur comprend trois cylindres hydrauliques a effet double avec une vanne rotative, le tout bâti sur un châssis. Les trois cylindres hydrauliques travaillent dans deux directions, une idée nouvelle qui a été brevetée; cela permet un rapport couple/densité plus fort. Un moteur prototype a opéré pendant une campagne a la sucrerie Havana Libre Sugar Mill de Cuba ; les résultats ont été très bons. Le papier donne aussi des détails sur un model plus robuste, promettant une performance supérieure comparée a celle du moteur prototype.

## MOTOR HIDRÁULICO DE ALTO TORQUE CON CILINDROS Y CIGUEÑAL

Por

G. ARIAS POLO

*Cubano Instituto de Investigación de Azúcar*

[gariaspolo@yahoo.com.mx](mailto:gariaspolo@yahoo.com.mx)

### **Resumen**

EL ARTÍCULO describe un nuevo diseño de motor hidráulico para las aplicaciones de alto torque y baja velocidad de rotación. Estos diseños no necesitan reducción de velocidad entre el motor y el equipo a mover. El motor es simple de construir y utiliza componentes de tecnología común, con bajo costo y pequeña complejidad. Consiste esencialmente en tres cilindros hidráulicos de doble efecto y una válvula de flujo rotatoria, todo soportado por un bastidor. Tiene la novedad patentada que los tres cilindros hidráulicos realizan trabajo útil en ambas direcciones de la carrera, resultando una superior densidad de torque/masa. Un prototipo de este motor ha operado durante una Zafra en el ingenio Habana Libre de Cuba, con resultados muy prometedores. También se presenta el diseño de un nuevo modelo más robusto, el que promete mucho mejor desempeño que el prototipo experimental.